

### 1B3. Coal Energy Application for Gas, Liquid and Electricity (EAGLE)

In charge of research and development: New Energy and Industrial Technology Development Organization; Electric Power Development Co.,Ltd.; The Center for Coal Utilization, Japan; and Babcock Hitachi K.K.  
 Project type: Coal Production and Utilization Technology Promotion Grant; and Grant for the Development of Advanced Technology for Generation of Fuel Gas for Fuel Cell Development  
 Period: 1995-2006 (12 years)

Outline of technology

1.1. Summary of technology

The multi-purpose coal gas production technology development (EAGLE) mentioned here aims, in an attempt to reduce environmental load, (particularly, to decrease the amount of greenhouse gas generated) at establishing a coal gasification technology which is widely applicable to chemical materials, hydrogen production, synthetic liquid fuel, electric power, and other purposes through the development of the most advanced oxygen-

blown, single-chamber, two-stage swirling flow gasifier that permits the high-efficiency production of synthetic gas (CO+H<sub>2</sub>). The application of this gasifier and its combination with gas turbines, steam turbines, and fuel cells further permit high-efficiency power generation [Integrated Coal Gasification Fuel Cell Combined Cycle (IGFC)], which will optimistically generate 30% less CO<sub>2</sub> emissions than that of existing thermal power plants.

2. Development targets and technology to be developed

When applying coal gasification gas for IGFC and synthetic fuel/hydrogen/chemical fertilizer production, it is necessary to set targets to meet the refinement level required by fuel cells as well as the catalyst since impurities contained in the gas such as sulfur compounds may poison fuel cells and the reactor catalyst, thereby weakening their performance. Although not so much has been reported, even globally, about the effects of fuel cell-poisoning materials (including halogen) in particular, the EAGLE Project has established development targets as listed in the table on the right with reference to DOE, MCFC Association, and other reports.

Target item	Target of development
Coal gasification performance	Gas calorific value: 10,000 kJ/Nm <sup>3</sup> or more Carbon conversion rate: 98% or more Cold gas efficiency: 78% or more Gasification pressure: 2.5 Mpa
Continuous operation performance	1,000 hours or more
Adaptability to various grades coal	Acquisition of gasification data for 5 or more grades coal having different properties from each other
Capability to scale up	Acquisition of data for scale up aiming at about 10 fold of scale up
Gas purification performance	Sulfur compounds: 1 ppm or less (precise desulfurizer outlet) Halogens: 1 ppm or less (precise desulfurizer outlet) Ammonia: 1 ppm or less (precise desulfurizer outlet) Dust: 1 mg/Nm <sup>3</sup> or less (precise desulfurizer outlet)

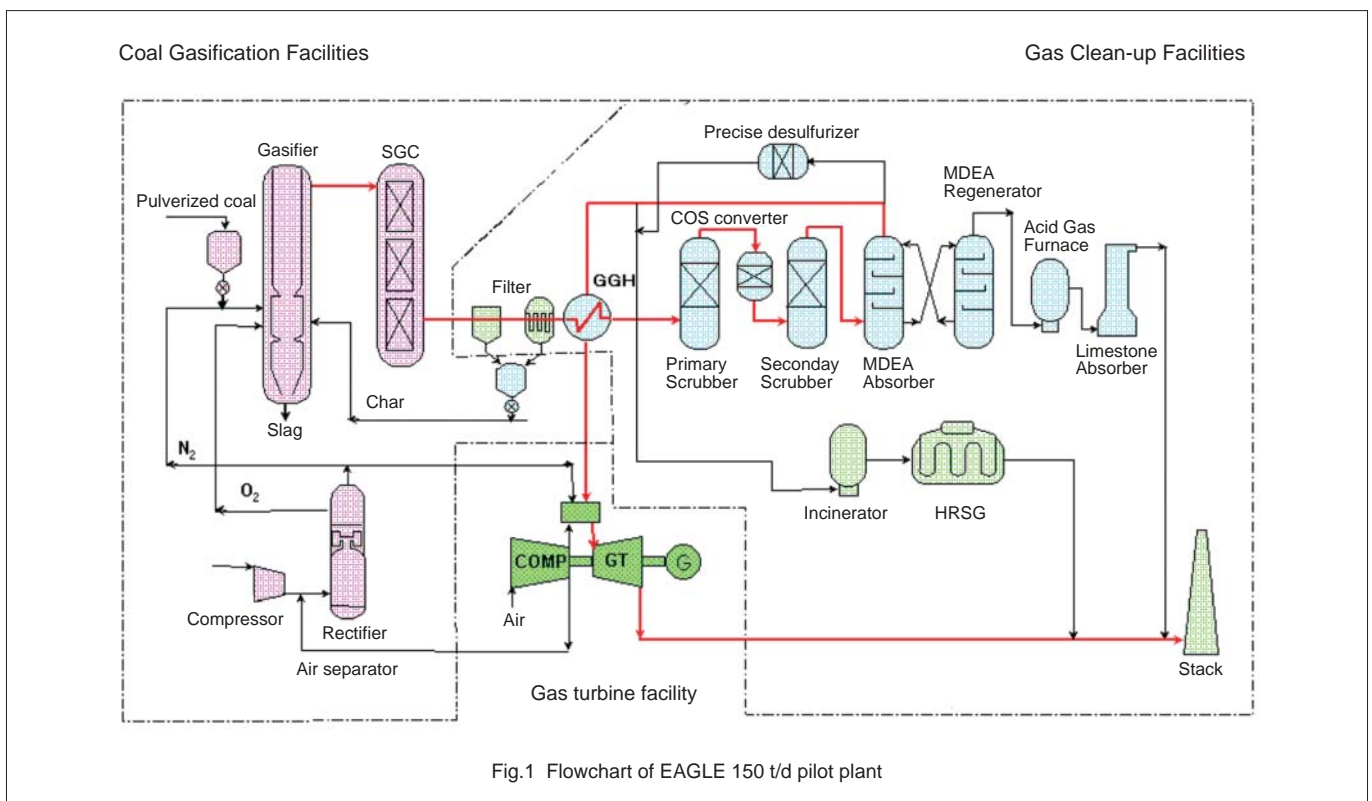

Fig.1 Flowchart of EAGLE 150 t/d pilot plant

**3.The Process and its Progress**

A joint team from New Energy and Industrial Technology Development Organization and Electric Power Development Co., Ltd. among others promotes the project. The pilot plant (150 t/d) was constructed on the grounds of the Wakamatsu Laboratory at

the Technology Development Center of Electric Power Development Co., Ltd., (refer to photograph). The plant is undergoing test operations.

EAGLE development schedule

Item	Fiscal year												
	1995	1996	1997	1998	1999	2000	2001	2002	2003	2004	2005	2006	
F/S	[Green bar spanning 1995-1996]												
Primary test	[Green bar labeled 'Test' spanning 1995-1996]												
Design of pilot plant	[Green bar labeled 'Design' spanning 1996-1997]												
Construction of pilot plant	[Green bar labeled 'Construction' spanning 1998-2001]												
Test operation	[Green bar labeled 'Test operation' spanning 2002-2005]												
													[Box labeled 'Final assessment' spanning 2005-2006]
													[Box labeled 'Analysis' spanning 2006]

**4.Future issues and the feasibility of practical application**

Through the acquisition of basic characteristics and performance, research and development is scheduled to acquire characteristics of various grade coal, to acquire, analyze, and evaluate data, and to establish operational control technology with stepwise confirmation of reliability and identification and

analysis of issues related to improved gasification performance and to long-term operation.

With respect to practical application and commercialization, active promotion will be enhanced based on the results of the testing, research, and development.



Photo 1 Total view of the pilot test facilities

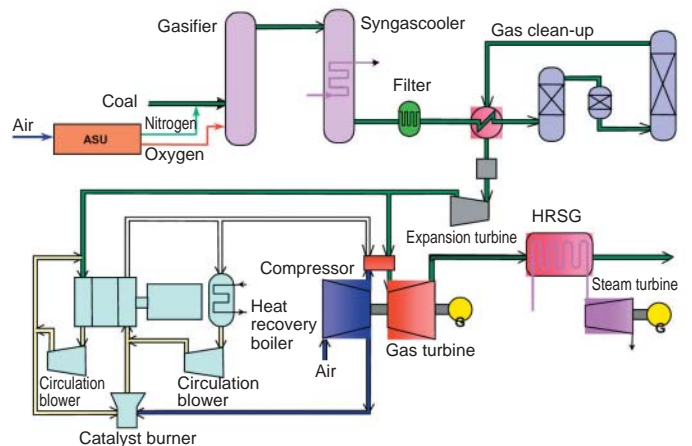

Fig.2 IGFC system

Reference

- 1) Masao Sotooka: Coal Gasification Technology (II) - Coal Energy Application for Gas, Liquid and Electricity (EAGLE), The Japan Institute of Energy, Vol.82, No.11, November, pp836-840, (2003)